

# DAMPA® Bandraster

## System overview

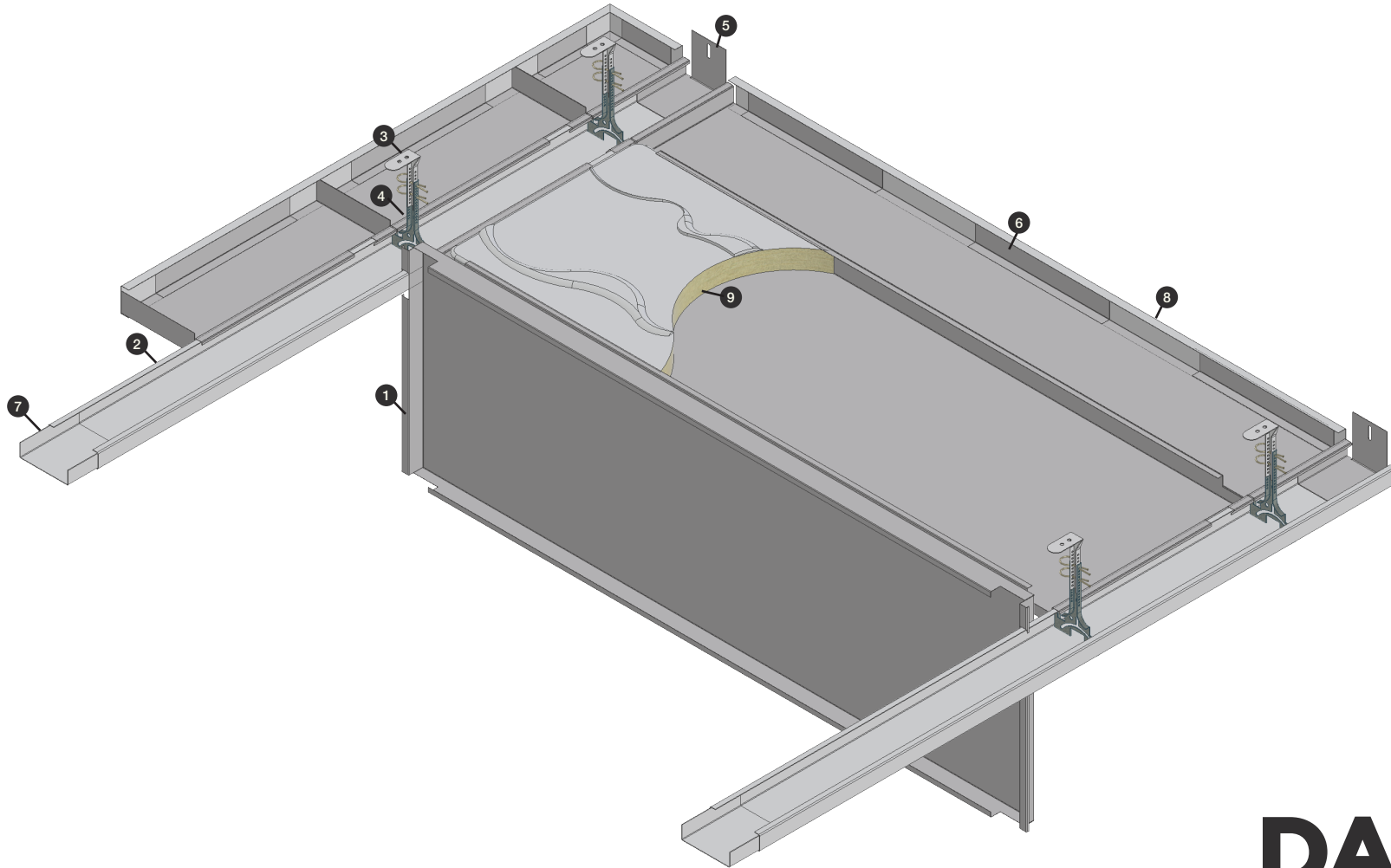

**DAMPA®**

DK-5690 Tommerup, Tel.: +45 63 76 13 00  
[dampa@dampa.dk](mailto:dampa@dampa.dk), [www.dampa.com](http://www.dampa.com)

# DAMPA® Bandraster Components

1

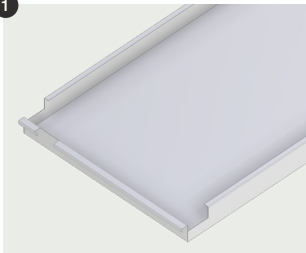

## Tile\*

Length: 600 - 3300 mm  
Width: 247 - 800 mm

We recommend that each individual tile does not exceed 2 m<sup>2</sup>

Material: 0.6 - 0.7 mm steel or aluminium

\*Shown with cut-out for service access above the ceiling, as per system overview.

2

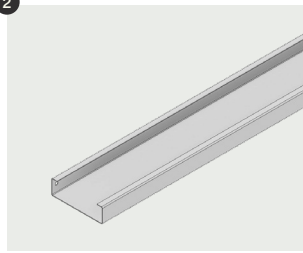

## Carrier

Size: 100 x 30 x 4000 mm

Material: 1.25 mm steel

3

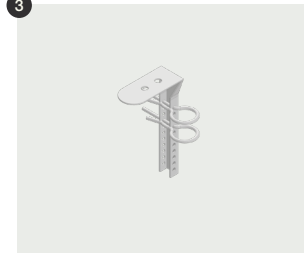

## Nonius upper part

Size: 56 x var. x 24 mm

Available in various heights between 150 and 2000 mm

Material: 1.25 mm steel

4



## Nonius lower part

Size: 25 x 140 x 98 mm

Material: 1.25 mm steel

5

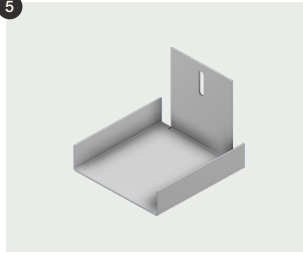

## Wall bracket

Size: 97 x 84 x 100 mm

Material: 1.25 mm steel

6

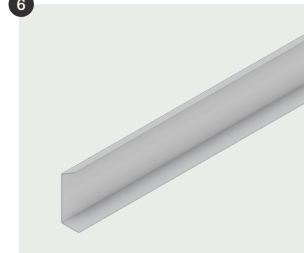

## Wedge

Size: 16 x 46.5 x 2740 mm

Material: 0.5 mm steel

7

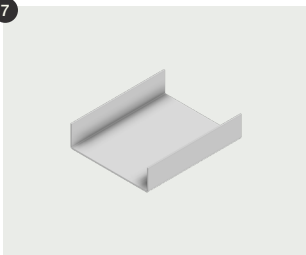

## Joining splice

Size: 99.5 x 27.5 x 120 mm

Material: 1.25 mm steel

8

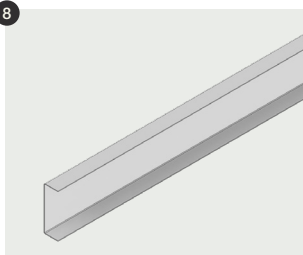

## Edge Trim No. 50

Size: 16 x 50 x 3000 mm

Material: 0.6 mm steel

9

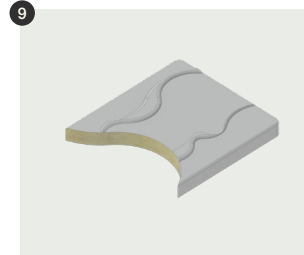

## Wool in sleeve\*

Size: 30 mm

Material: 35 kg/m<sup>3</sup> stone wool

\*Shown with wool in sleeves. Also available without inlay or with alternative acoustic inlay.