

DAMPA®
Marine Ceiling Systems



Technical Information
DAMPA 10/200/300
Decorative Marine Ceiling System

DAMPA 10/200/300 Marine Ceiling System

Consists of different modular units which can be installed on the same Modular Carrier No. 40 in any combination offering many possible design and functional applications.

DAMPA 10 ceiling units are as standard supplied without end closing, whereas DAMPA 200/300 ceiling units are end closed.

DAMPA 10

Consists of 100 mm modular ceiling units - suitable for flat as well as curved configurations - offering many possible design and functional applications. The ceiling units are manufactured in any length from 600 mm up to 5000 mm as standard, shorter or up to 6000 mm on request.

They are available either in individual length to fit actual room dimensions or standard lengths according to specifications.

DAMPA 10 ceiling units are as standard supplied without end closing.

Type N

0.45 mm aluminium units.
Perforated with 1.0 mm holes at 2 mm centres, open area 22%.

With black acoustic felt bonded to the reverse side.
Weight 1.5 kg per sq.m.

Type O

0.45 mm aluminium units.
Unperforated.
Weight 1.7 kg per sq.m.

Type P

0.45 mm aluminium units.
Perforated with 1.0 mm holes at 2 mm centres, open area 22%.

With acoustic felt bonded to the concealed surface using non-toxic waterproof glue. With air injection slots in the wide flange in one row of 3 x 7 mm at 10 mm centres providing a free injection area of 0.0021 sq.m/lin.m unit.

With inlay of 12 mm mineral wool sealed in PE-sleeves.
Weight 1.8 kg per sq.m.

Type Q

0.45 mm aluminium units.
Unperforated.

With air injection slots in the wide flange in one row of 3 x 7 mm at 10 mm centres providing a free injection area of 0.0021 sq.m/lin.m unit.
Weight 1.7 kg per sq.m.

Optional Extra

Ceiling units to be installed in combination with perforated ceiling units with air injection slots (type P) are to be supplied with mineral wool sealed in PE-sleeves.

All ceiling units can as optional extra be supplied with inlay of 12 mm mineral wool, to obtain even higher sound absorption.
Weight 0.3 kg per sq.m.

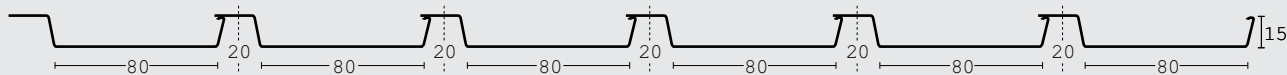

DAMPA 200/300

Type 203/303

0.55/0.70 mm aluminium units.
Perforated with 1.0 mm holes at 2 mm centres, open area 22%.

With acoustic felt bonded to the concealed surface using non-toxic waterproof glue.
Weight 1.5/1.8 kg per sq.m.

With acoustic felt bonded to the concealed surface using non-toxic waterproof glue.

With two rows of 3 x 7 mm air injection slots in the wide flange at 10 mm centres providing a free area of 0.0042 sq.m/lin.m unit plus inlay of 12 mm mineral wool sealed in PE-sleeves.
Weight 1.8/2.1 kg per sq.m.

Optional Extra

Ceiling units to be installed in combination with perforated ceiling units with air injection slots (type 205/305) are to be supplied with mineral wool sealed in PE-sleeves.

All ceiling units can as optional extra be supplied with inlay of 12mm mineral wool, to obtain even higher sound absorption.
Weight 0.3 kg per sq.m.

Type 204/304

0.55/0.70 mm aluminium units.
Unperforated.
Weight 1.8/2.2 kg per sq.m.

Type 206/306

0.55/0.70 mm aluminium units.
Unperforated.

With two rows of 3 x 7 mm air injection slots in the wide flange at 10 mm centres providing a free injection area of 0.0042 sq.m/lin.m unit.
Weight 1.8/2.2 kg per sq.m.

Type 205/305

0.55/0.70 mm aluminium units.
Perforated with 1.0 mm holes at 2 mm centres, open area 22%.

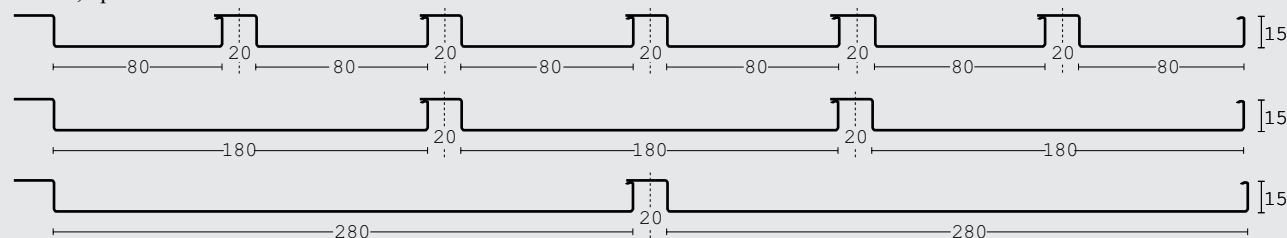

Installation Principles

DAMPA 10/200/300 ceiling units can all be installed in any combination on the same Modular Carrier No. 40 with a minimum of suspension points due to the well-proven rigid and easily adjustable suspension principle identical to the fire rated DAMPA DCC 300/200 Ceiling System.

After fixing of the perimeter trims, the modular carriers are suspended.

When using either Edge Trim No. 13 or Angle Runner No. 1 and No. 2, a slot is cut at the ends of Modular Carrier No. 40 to splice into the horizontal flange of the edge trim or of the angle runner.

Perimeter Details

Where ceiling lengths can be predetermined, use Angle Runner No. 1 transversely to ceiling units with a shadow freeze to accommodate building tolerances.

Where ceiling units have to be cut, use Edge Trim Type 2 parallel to ceiling units and Type 1 transversely. Both types can be secured directly to the wall or if a shadow freeze is required, on to the Edge Trim No. 13 or Angle Runner No. 2.

Installation of Ceiling Units

DAMPA 10/200/300 ceiling units are normally installed progressively, starting at either end of the room.

Ceiling units can, however, be left out to be installed later.

Dismantling

It is possible to remove and reinstate individual ceiling units without the use of tools.

To remove, pull the unit towards you horizontally and simultaneously push the nearest adjacent one.

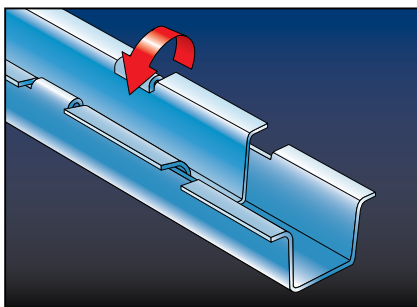

Splicing of Carriers

Modular Carrier No. 40 is provided with pre-punched lugs and cutouts for modular splicing.

Locate the carrier ends so that the cutouts overlap and lock together by folding the lugs inwards.

Built-In Heights

The minimum constructional height of a DAMPA 10/200/300 Ceiling System, which is installed directly to possible existing gridwork, is 21 mm by use of Modular Carrier No. 44 and 41 mm by use of Modular Carrier No. 40.

Weight

The average weight of a DAMPA 10/200/300 ceiling including suspension components is as low as 2.7 - 3.4 kg per sq.m depending on type and execution.

For possible specific project-related weight calculations, please see the weight of each item.

Sound Absorption

To reduce the general sound level and reverberation time within a room, perforated ceiling units are the most effective solution.

Unperforated ceiling units offer sound absorption in the low frequency range.

Perforated ceiling units offer good sound absorbing characteristics within the normal frequency range.

Air Injection

DAMPA 10/200/300 ceiling units with air injection slots give an even distribution of air.

Such ventilation solutions are both elegant and cost-effective in areas where the ceiling void is used as air supply chamber.

Colours and Surfaces

Ceiling units are stove-enamelled using non-toxic polyester paint providing excellent paint finish and surface protection.

DAMPA's standard colour is Pure White matt No. 4747-2 similar to RAL 9010. Almost any colour shade is available on request. For anodised surfaces and other possible finishes, please contact DAMPA.

Classification

Approved as C-class material by leading classification societies and national administrations.

This includes both perforated and unperforated executions, with or without bonded acoustic felt and/or inlay of mineral wool, whether sealed in PE-sleeves foil or not.

Packaging

Ceiling panels and painted perimeter trims are supplied in rigid, non returnable cardboard boxes.

Galvanised suspension components are supplied in standard bundles.

All materials to be stored under cover in a dry, ventilated area.

Identification and Handling on Site

Ceiling unit boxes are labelled with contents, ceiling unit length as well as deck and room number for easy identification and handling on site. Please contact DAMPA with your specific requirements.

Functionality and Quality

All DAMPA Marine Ceiling Systems are manufactured to high standards within close tolerances to ensure accurate, fast and reliable installation. The DAMPA Marine Ceiling Systems are produced according to DAMPA's Quality Management System in accordance with DS/EN ISO 9001:2008

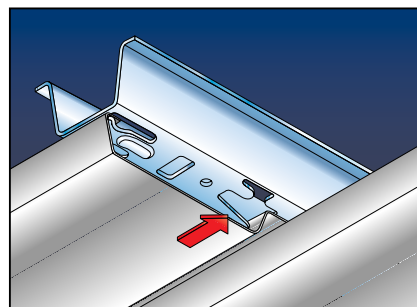

Securing the Units

If necessary, the ceiling units can be locked in position by pushing down the reverse clip behind the wide flange.

For DAMPA 10 use the longer reverse clips and for DAMPA 200/300 use the shorter of the two.

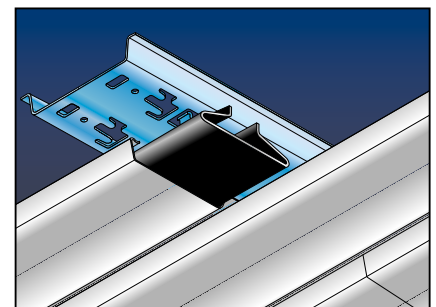

Closed Jointing Details

Closed joints are formed under Modular Carrier No. 43 (double carrier) rigidly suspended from the deckhead above.

Only the DAMPA 10 ceiling, using a splice inlay, can be butt jointed without end closings.

Locate the splice inlay in the unit and hold in position while securing to carrier. Install second unit to complete closed joint. The splice inlay must not be pushed into the units after installation.

Carrier and Hanger Distances

All carrier and hanger centres are maximum distances.

A: Wall to first hanger600 mm

B: Hanger to hanger1200 mm

C: Wall to first Modular Carrier No. 40 in connection with:

Edge Trim No. 13300 mm

Edge Trim Type 1300 mm

Angle Runner No. 11200 mm

D: Modular Carrier No. 40 to next

Carrier No. 401200 mm

If luminaires, air diffusers or integrated fittings are incorporated into the ceiling, it may be necessary to provide additional hangers to accommodate the extra weight.

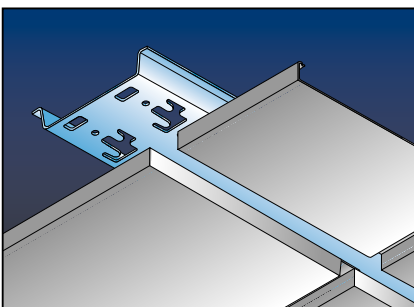
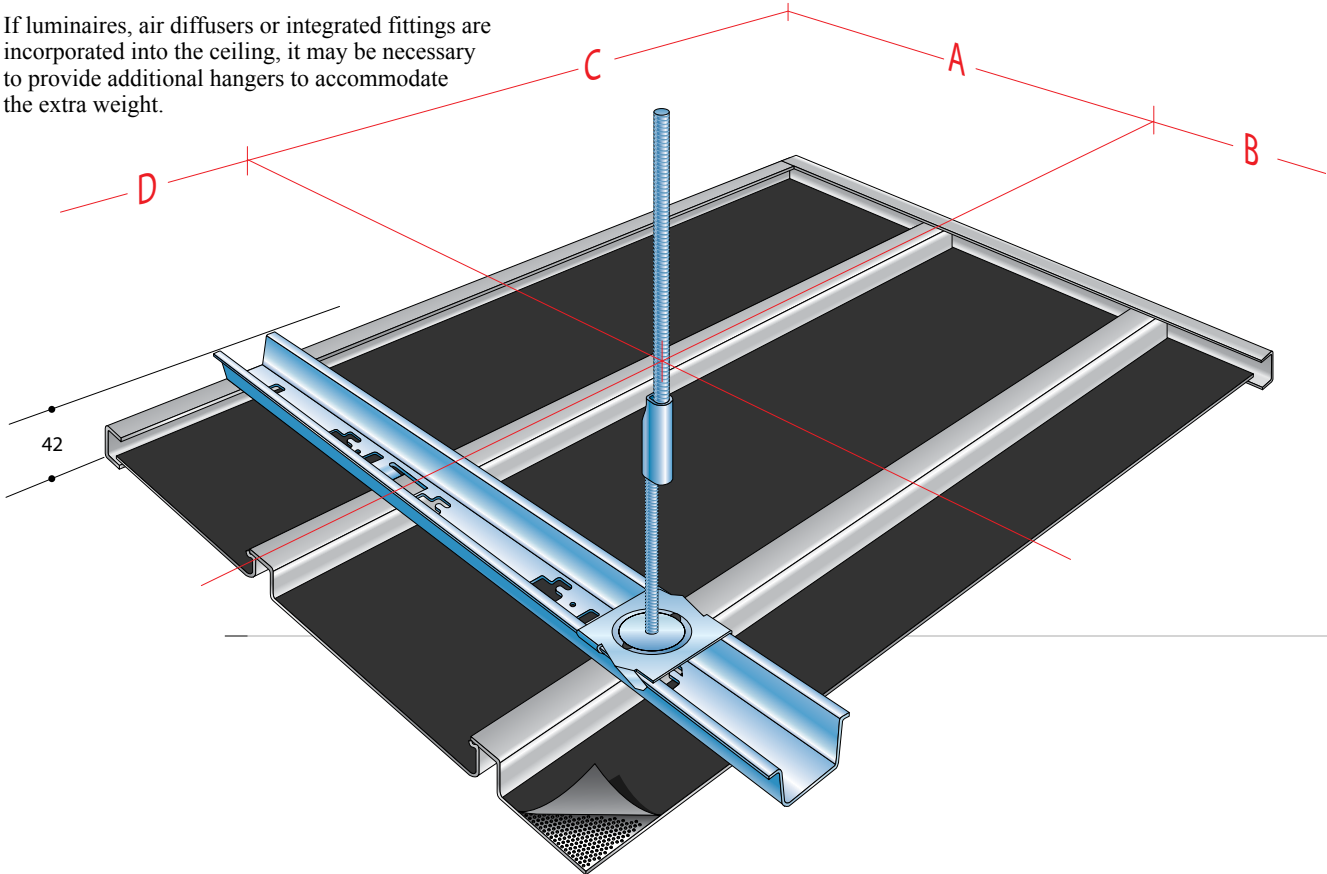

Featured Joint

Featured joints of DAMPA 200 and 300 ceiling units are formed under Modular Carrier No. 43 (double carrier) rigidly suspended from the deckhead above.

In this case the carriers are to be ordered in painted execution.

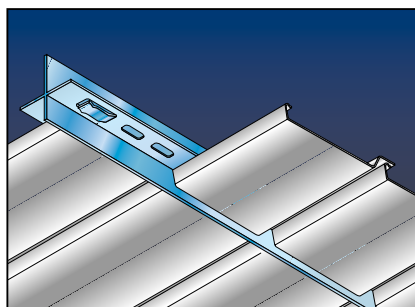

Jointing Detail Using Pluschannel Type 3

This jointing principle is suitable for all DAMPA 10/200/300 ceiling units. The ceiling units are engaged into the clips of the Pluschannel Type 3, rigidly suspended from the deckhead above.

The distance between pluschannels and modular carriers or two pluschannels must not exceed 300 mm.

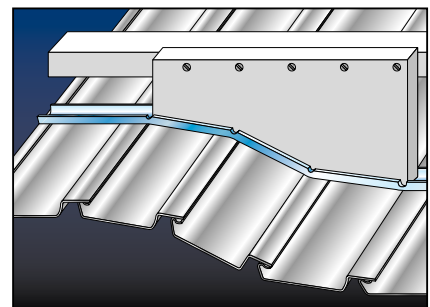

Curved

DAMPA 10 ceiling units can be installed as concave or convex curved surfaces down to a minimum radius of 500 mm using Modular Carrier No. 44.

The carrier is fastened at 300 mm centres to a pre-shaped hard core or metal structure spaced at 1200 mm centres maximum. Curved surfaces of DAMPA 10/200/ 300 ceiling units to a radius of 20 m or more, corresponding to an arch of 100 mm over a span of 4 m, may be formed with standard Modular Carrier No. 40 suspended from standard hangers.



DAMPA 10 100 mm modular ceiling units - suitable for flat as well as curved configurations.



DAMPA 200 200 mm modular ceiling units.



DAMPA 200/300 200/300 mm ceiling units can all be installed in any combination on the same carrier.

Modular Carrier No. 40

Height : 26 mm
 Width : 52 mm
 Length : 4000 mm
 Weight : 0.43 kg/
 lin.m
 Material : 0.6 mm galvanised steel

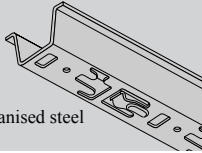
**Modular Carrier No. 43**

Height : 26 mm
 Width : 124 mm
 Length : 4000 mm
 Weight : 0.83 kg/
 lin.m
 Material : 0.6 mm galvanised steel

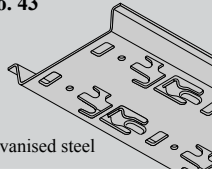
**Angle Runner No. 1**

Height : 38 mm
 Width : 80 mm
 Length : 4000 mm
 Weight : 0.92 kg/
 lin.m
 Material : 1.0 mm galvanised steel,
 stove-enamelled black

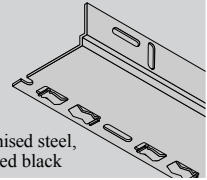
**Suspension No. 1**

Total height : 150 mm
 Weight : 0.05 kg/each
 Material : Galvanised steel

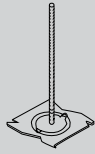
**Splice No. 12**

(for Modular Carrier No. 43)

Height : 20 mm
 Width : 36 mm
 Length : 321 mm
 Weight : 0.17 kg/each
 Material : Galvanised steel

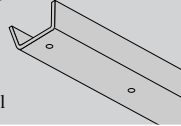
**Angle Runner No. 2**

Height : 38 mm
 Width : 80 mm
 Length : 4000 mm
 Weight : 0.92 kg/
 lin.m
 Material : 1.0 mm galvanised steel,
 stove-enamelled black

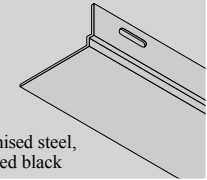
**Rod Clip No. 2**

Total length : 50 mm
 Weight : 0.015 kg/each
 Material : Galvanised steel

**Pluschannel Splice**

Height : 20 mm
 Width : 20 mm
 Length : 300 mm
 Material : Aluminium
 Inclusive of screws and nuts

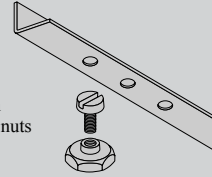
**Edge Trim No. 13**

Height : 40 mm
 Width : 55 mm
 Length : 4000 mm
 Weight : 0.78 kg/
 lin.m
 Material : 1.0 mm galvanised steel,
 stove-enamelled black

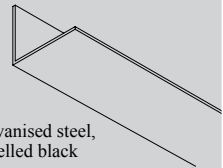
**Threaded Rod M8**

Diameter : 8 mm
 Length : 200, 300, 400
 500, 600 and
 2000 mm
 Weight : 0.30 kg/lin.m
 Material : Galvanised steel

**Modular Carrier No. 44**

(Module 100 for curved configurations)

Height : 5.5 mm
 Width : 52 mm
 Length : 4000 mm
 Weight : 0.22 kg/lin.m
 Material : 0.6 mm galvanised steel

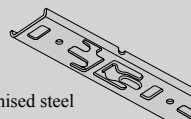
**Edge Trim Type 1**

Height : 16 mm
 Width : 15 mm
 Length : 4000 mm
 Weight : 0.09 kg/lin.m
 Material : 0.7 mm aluminium,
 chromated and stove-enamelled

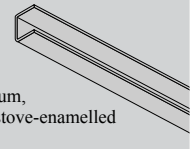
**Suspension No. 4**

(with vibration absorbing rubber bush)

Total height : 32 mm
 Diameter : 6 mm std. M6 pitch
 Weight : 0.05 kg/each
 Material : Galvanised steel
 (Not to be used in combination with
 Rod Clip No. 2 and Threaded Rod M8)

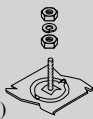
**Pillar Ring**

Height : 16 mm
 Diameter : 200-1000 mm
 Material : 0.7 mm
 aluminium,
 chromated
 and stove-enamelled

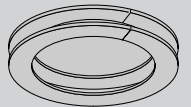
**Edge Trim Type 2**

Height : 16 mm
 Width : 15 mm
 Length : 4000 mm
 Weight : 0.09 kg/lin.m
 Material : 0.7 mm aluminium,
 chromated and stove-enamelled

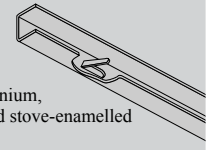
**Access Hatch**

Width : 600 mm
 Length : 600 mm
 Material : Galvanised
 steel

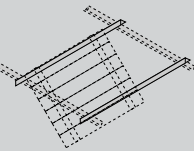
**Circular Speaker Grille**

Diameter: 156 mm
 Material: Galvanised steel,
 stove-enamelled in ceiling
 colour. Applicable for
 module 200/300 units.

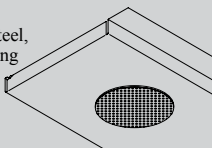
**Adapter Panel**

Height : 16 mm
 Size : 300×300 mm
 400×400 mm
 600×600 mm
 Material : Galvanised steel,
 stove-enamelled. Colour to
 be stated.

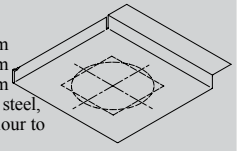

All products are subject to modifications
 without prior notice.



DAMPA®

Marine Ceiling Systems

DAMPA, DK-5690 Tommerup

Phone: +45 63 76 13 20, fax: +45 63 76 13 99, dampa@dampa.dk, www.dampa.dk